

FKHQ Series Narrow Opening Parallel Grippers

**NEW
 PRODUCT**

Features

1. Magnetic piston is standard feature.
2. Adding optional sensors enables "open" and "close" position sensing.
3. Compact design make grippers ideal for handling small parts in confined areas.
4. Gripper body is hardcoated aluminum ensuring abrasion and corrosion resistance.
5. No extra lubrication required.



Specifications

100 PSI MAX.

Model	FKHQ			
Action	Double acting			
Bore (mm)	ø10	ø16	ø20	ø25
Media	Compressed air			
Min. operating pressure	30 psi			
Max. operating pressure	0.7 MPa (7 kgf/cm ²) 100 psi			
Ambient & media temperature	-10°C(14°F) ~ +60°C(140°F) Use filtered dry air			
Lubrication	None required or use ISO VG32			
Port size	M3x0.5	M5x0.8		
Opening	Parallel - See dimensions pages 2 & 3			
Close - stroke (mm)	4.6	7.9	9.6	13.9
External grip force (lbf) *	2.4	7.6	9.4	14.6
Internal grip force (lbf)*	3.8	10.1	14.8	23.3
Weight g (ounce)	55(1.9)	115(4.1)	235(8.3)	430(15.2)

Sensors

See specifications and prices in the sensor selection guides on page 3. Please order sensors and female cordsets separately.

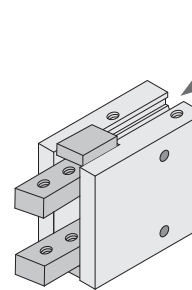

Sensors fit into mating slots in the gripper housing. The low profile and in-line wire outlet provides minimal intrusion for close mounting of adjacent components.

*Note: Grip force at 72 psi, at center of stroke and gripping point 20mm from gripper face.

How to Order

FKHQ - 16 D

Series	Bore	Action
Narrow opening parallel jaw type 	ø10	D Double Acting
	ø16	
	ø20	
	ø25	

Specifications and prices subject to change without notice or incurring obligation.

Prices

See sensor specifications, selection guide and pricing on page 3. Please order sensors and female cordsets separately.

Model	Price
FKHQ-10D	\$128.25
FKHQ-16D	120.55
FKHQ-20D	171.80
FKHQ-25D	192.35

FKHQ-10D

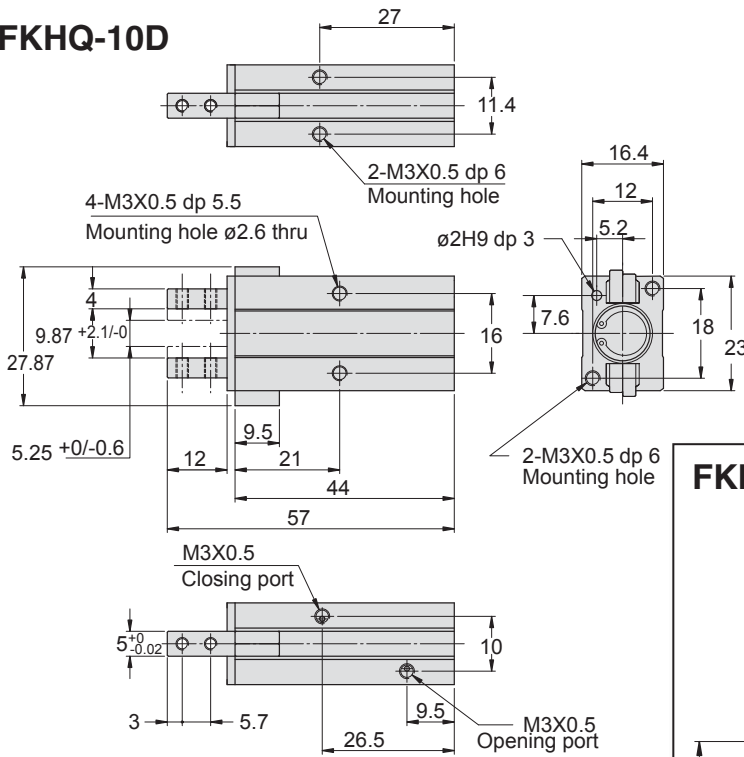

*Note 1:
When using sensors,
thru-hole mounting
is not possible.

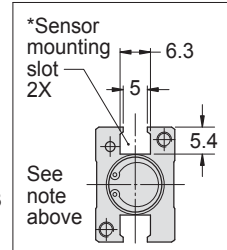

FKHQ-16D

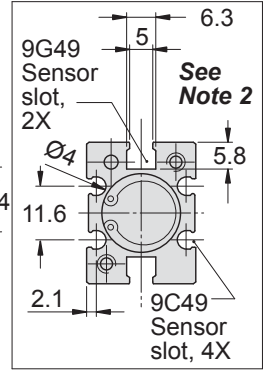
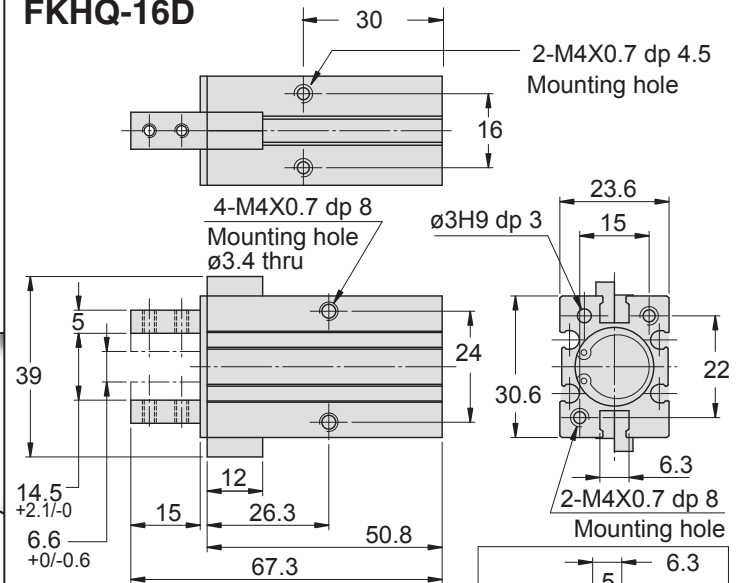

FKHQ-20D

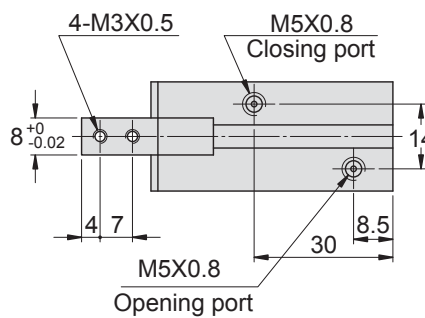
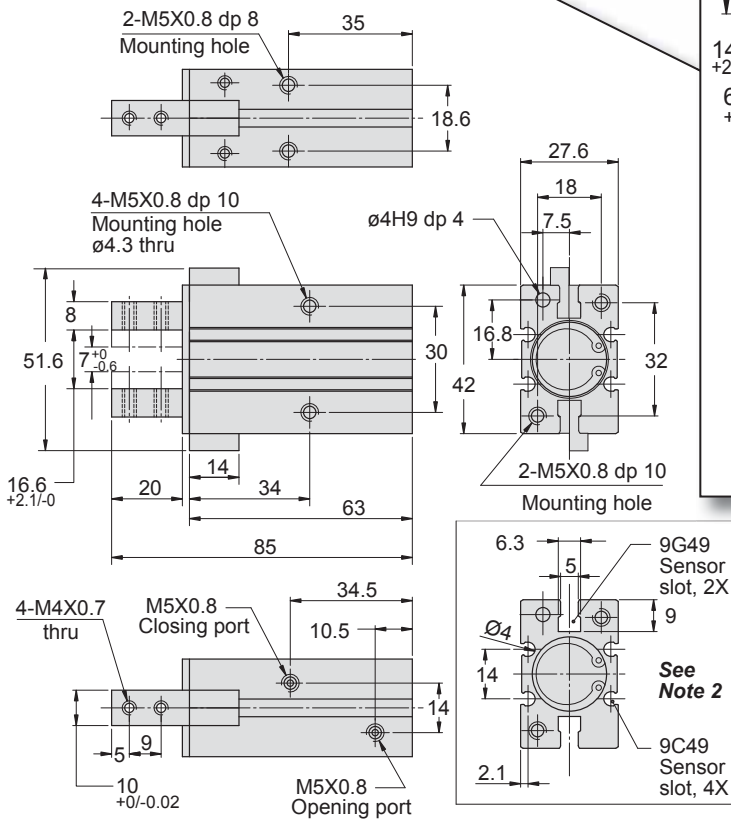

*Note 2:
Thru-hole mounting is not possible when using
the sensor in the 6.3mm wide mounting slots.

Specifications and prices subject to change
without notice or incurring obligation.

FKHQ Series Dimensions (mm) & Sensor Selections

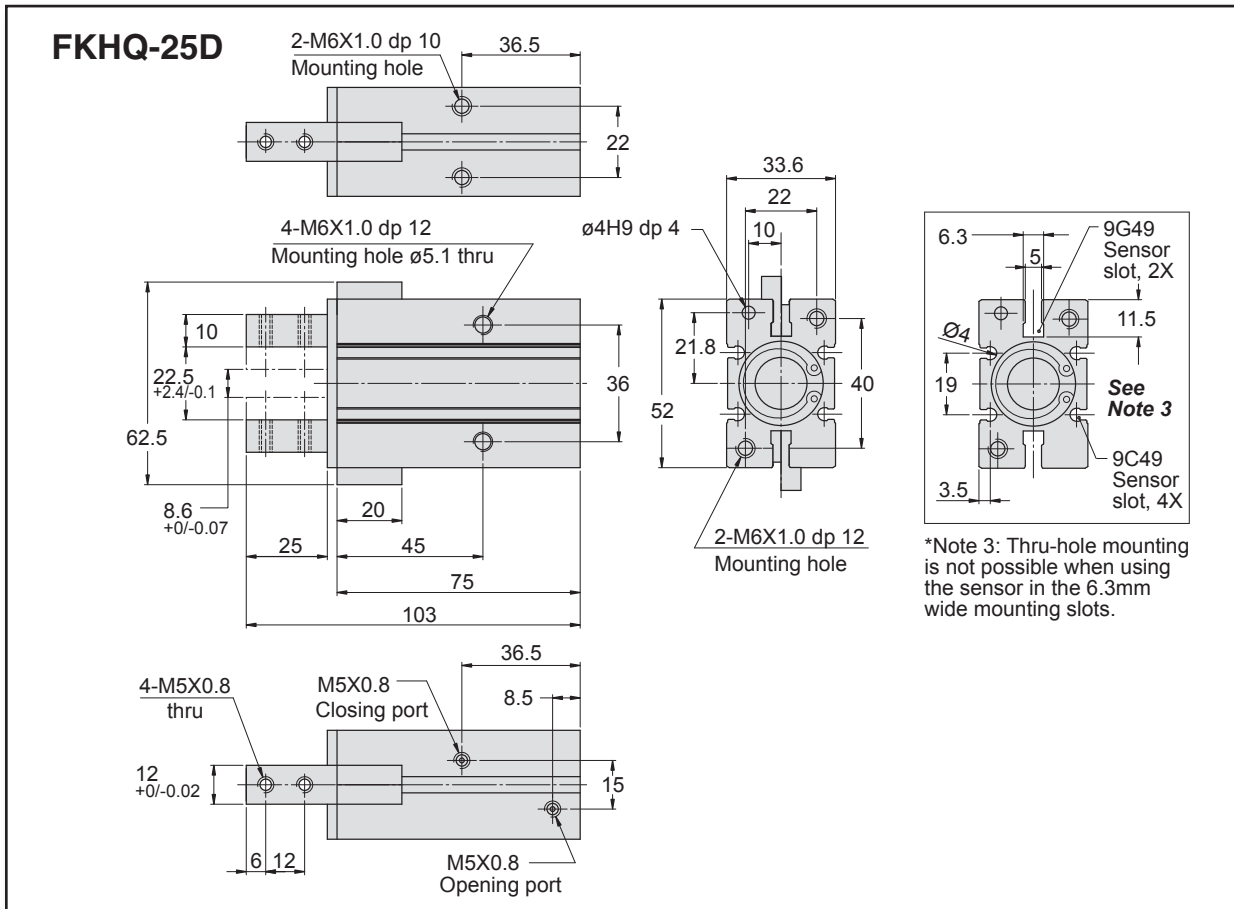

Sensors

See specifications and prices in the sensor selection guides below. Please order sensors and female cordsets separately.

9G49 Sensors

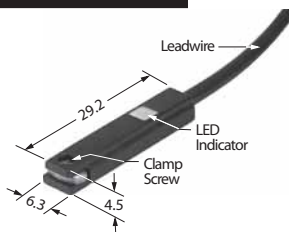

9C49 Sensors

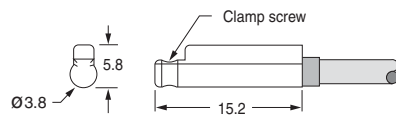

All 9C49 sensors feature surge protection, polarity protection, LED indicator, and extremely fast switching speeds.

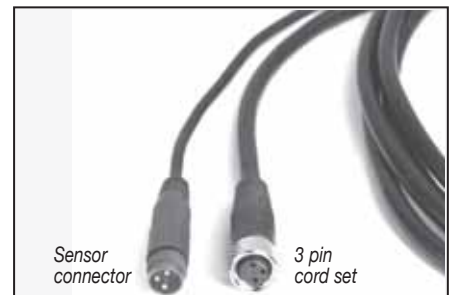

Female Cord Sets	Part No.	Price
1 Meter	CFC-1M	\$14.35
2 Meters	CFC-2M	16.05
5 Meters	CFC-5M	20.30

9G49 Sensor Selection Guide for all bore sizes $\phi 10 \sim \phi 25$		Prewired 9 ft. Leadwire	Quick Disconnect*
Sensor Type	Electrical Characteristics	Part No.	Part No.
Reed (LED)	5-120 VDC/VAC, 0.03 Amp max, 0.005 AMP min, 4 Watt max., 2.0 voltage drop	9G49-000-002 \$14.00	9G49-000-302 \$16.50
Electronic (LED)	Sourcing PNP 5-28 VDC, 0.20 Amp max current, 0.5 voltage drop	9G49-000-031 27.45	9G49-000-331 29.95
Electronic (LED)	Sinking NPN 5-28 VDC, 0.20 Amp max current, 0.5 voltage drop	9G49-000-032 27.45	9G49-000-332 29.95

9C49 Sensor Selection Guide for bore sizes $\phi 16 \sim \phi 25$		Prewired 9 ft. Leadwire	Quick Disconnect*
Sensor Type	Electrical Characteristics	Part No.	Part No.
Reed (LED)	5-120 VDC/VAC, 0.04 Amp max, 0.005 Amp min current, 4 Watt max., 2.5 voltage drop	9C49-000-002 \$19.30	9C49-000-302 \$25.70
Electronic (LED)	Sourcing PNP 6-30 VDC, 0.2 Amp max current, 6 Watt max., 1.5 voltage drop	9C49-000-031 27.30	9C49-000-331 31.65
Electronic (LED)	Sinking NPN 6-30 VDC, 0.2 Amp max current, 6 Watt max., 1.5 voltage drop	9C49-000-032 27.30	9C49-000-332 31.65

*Note: All quick disconnect style sensors are supplied with 6 inch pigtail with male connector.



Cylinders, Valves and Accessories
 Catalog #CV9

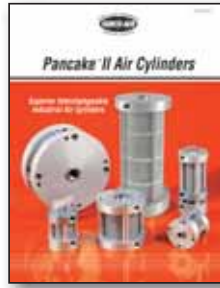

Pancake® II Air Cylinders
 Catalog Pan2-2



Square Pancake® II Air Cylinders
 Catalog # SqPan2



ISO 6431 Cylinders
 Catalog # FAQR-09



Twin Rod, Non-Rotating Air Cylinders - Catalog # FDF-09 and Catalog # FDXS-09



Multi-Power® Air Presses
 Catalog # FP16



Linear Slides - 6 Families
 Catalog # LS-03

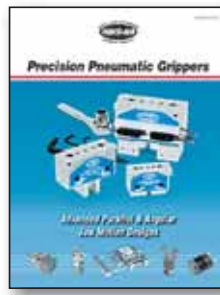

Pneumatic Grippers, Parallel Jaw and Angular Motion - Catalog # GR-8

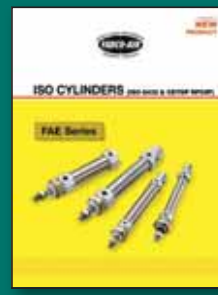

ISO 6432 Cylinders
 Catalog # FAE-09

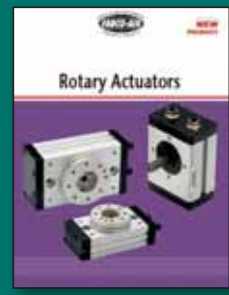

Rotary Actuators, Pneumatic
 Catalog # FRA-C-09



NFPA Interchangeable Air Cylinders - Catalog # NF-6

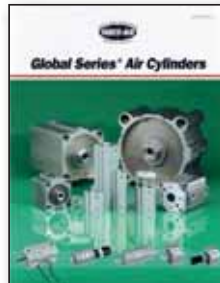

Global Series™ Metric Air Cylinders - Catalog # GC-15



Stopper Cylinders
 Catalog # ST-SC



Angular Grippers
 Catalog # FKA-09



Air Table Slides
 Catalog # FGXS-10



Modular Air Preparation System - FRLs
 Catalog # FRL-06

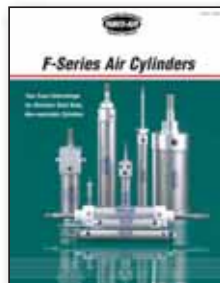

Stainless Steel Body Air Cylinders
 Catalog # SSB-03

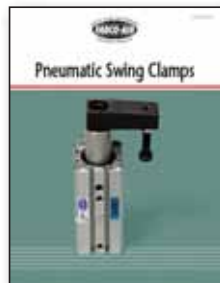

Swing Clamps
 Catalog # SC-DB04

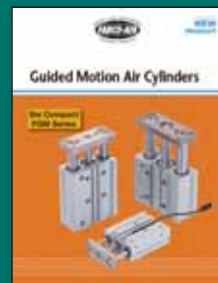

Guided Motion Air Cylinders
 Catalog # FGM-10



Pneumatic & Hydraulic Swing Clamps
 Catalog # FML-H

Check out these new product lines today !