



# ***PNEUMATIC ROTARY ACTUATORS***

**FRA  
&  
FRC  
Series**





## Specifications

100 psi max.

Model	FRA					
Action	Double acting with magnetic piston					
Bore Size	ø16	ø20	ø25			
Media	Compressed air					
Min. operating pressure	1.5 kgf/cm <sup>2</sup> (0.15 Mpa) 21psi	0.6 kgf/cm <sup>2</sup> (0.06 Mpa) 9psi				
Max. operating pressure	7 kgf/cm <sup>2</sup> (0.7 Mpa) 100 psi					
Typ. rotational speed	(at 71 psi - no load) 0.2~1 sec/90°					
Temperature range	-10°C(14°F) ~ +70°C(158°F) filtered dry air					
Lubrication	None required					
Output torque	See chart on page 3					
Allowable kinetic energy	0.03kgf.cm(0.026lbf.in)	0.08kgf.cm(0.069lbf.in)	0.15kgf.cm(0.130lbf.in)			
Weight	300g	355g	431g	515g	682g	824g

### Conversions

psi = kgf/cm<sup>2</sup> x 14.2  
psi = MPa x 145

inch = mm x 0.0394  
ounceforce-in = kgf.cm x 13.9  
ounce = g x 0.035

## Price List

Rotation Angle	FRA16	FRA20	FRA25
90°	\$111.15	\$151.20	\$182.15
180°	122.25	166.70	198.85

Sensor Selection Guide		Prewired 9 ft. Leadwire Part No.	Price	Quick Disconnect* Part No.	Price
Reed (LED)	5-120 VDC/VAC, 0.03 Amp Max current, 4 Watt Max., 2.0 voltage drop	9P49-000-002. . .	\$13.30	9P49-000-302 ..	\$15.80
Electronic (LED)	Sourcing PNP 5-28 VDC, 0.20 Amp Max current, 0.5 voltage drop	9P49-000-031. . . .	25.80	9P49-000-331.....	28.30
Electronic (LED)	Sinking NPN 5-28 VDC, 0.20 Amp Max current, 0.5 voltage drop	9P49-000-032. . . .	25.80	9P49-000-332.....	28.30

\*Note: Quick disconnect styles are supplied with 6 inch pigtail with male connector.

## Features

1. **Magnetic pistons are standard on all models.**
2. Compact design saves space.
3. Rectangular body design has end caps with ports in one end and adjusting screws at opposite end.
4. Rack and pinion mechanism designed to minimize backlash.
5. Adjustments for rotation angles to fit your application.

## How to order

<b>FRA</b>	<b>20</b>	<b>X</b>	<b>90</b>
Series	Bore	Rotation angle	
FRA standard type 	ø16 ø20 ø25	90° 180°	

## Position Sensors

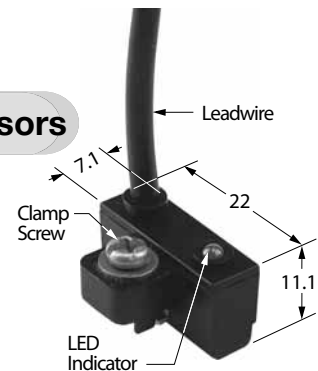

See specifications in the sensor selection guide below. Please order sensors and female cordsets separately from charts below.

Female Cord Sets	Part No.	Price
1 Meter	CFC-1M	\$14.35
2 Meters	CFC-2M	16.05
5 Meters	CFC-5M	20.30

## Dimensions (mm)

- FRA16x90...  $\overset{I}{70}$  ...  $\overset{C}{30.5}$
- FRA16x180...  $\overset{I}{86}$  ...  $\overset{C}{35.5}$

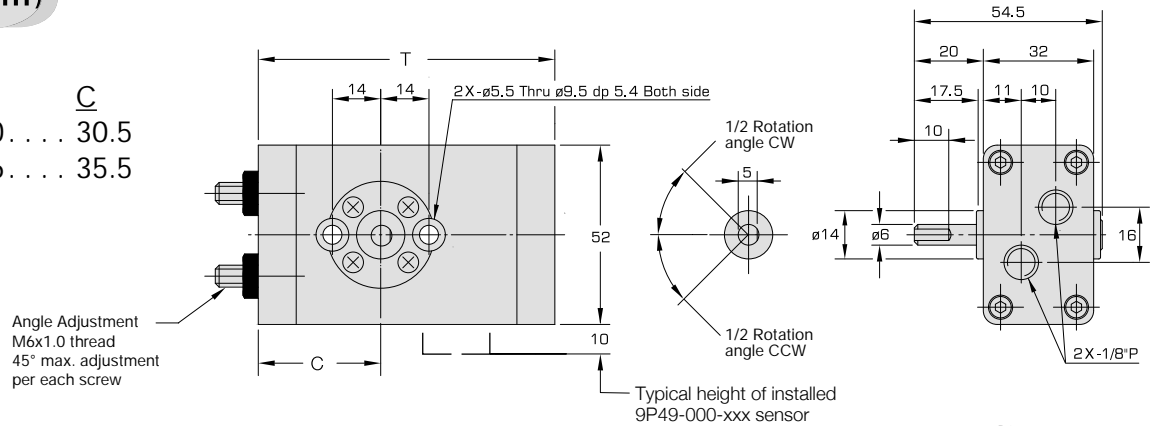

- FRA20x90...  $\overset{I}{81}$  ...  $\overset{C}{34.5}$
- FRA20x180...  $\overset{I}{103}$  ...  $\overset{C}{44}$

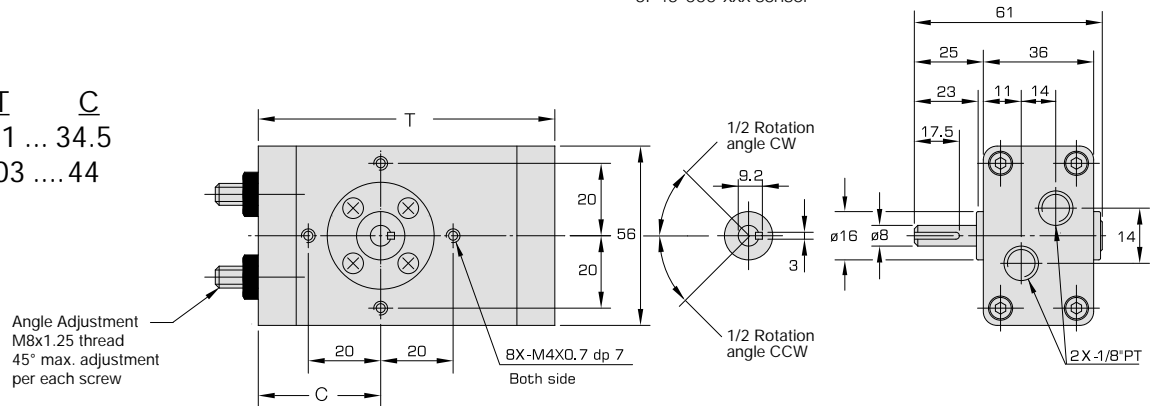

- FRA25x90...  $\overset{I}{94}$  ...  $\overset{C}{40}$
- FRA25x180...  $\overset{I}{120}$  ...  $\overset{C}{52}$

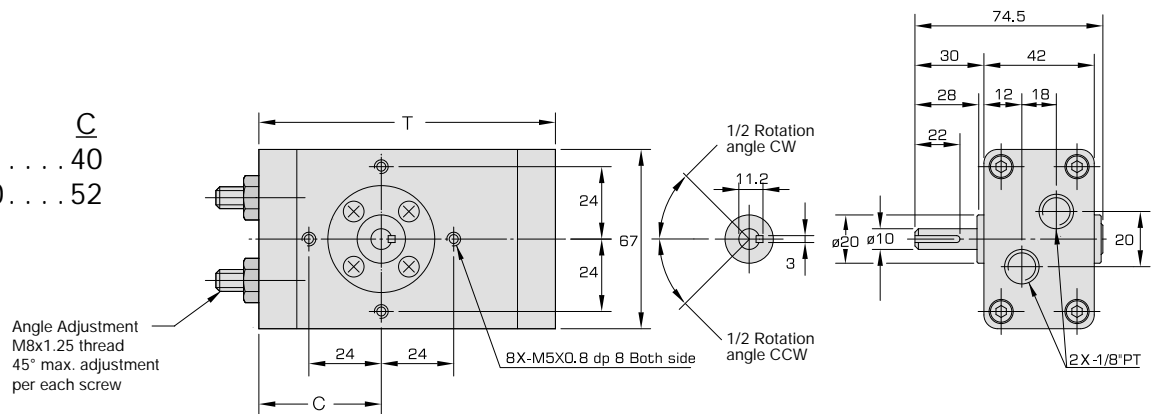

## Output

lbf-in  
 (kgf-cm)

Bore	16	20	25
50psi (0.35MPa)	3.0 (3.4)	6.1 (7.0)	12.2 (14.0)
71psi (0.5MPa)	4.3 (5)	8.7 (10)	17.4 (20)
100psi (0.7MPa)	6.0 (6.9)	12.2 (14.0)	24.5 (28.2)

Conversions:  
 MPa = psi x 0.7  
 kgf-cm = lbf-in x 1.15



## Specifications

150 psi max.

Model	FRC				
Action	Double acting with magnetic piston				
Bore Size	ø16	ø20	ø25	ø32	ø40
Media	Compressed air				
Max. operating pressure	10.2 kgf/cm <sup>2</sup> (1Mpa) 150 psi				
Min. operating pressure	1 kgf/cm <sup>2</sup> (0.1Mpa) 15 psi				
Adjustable rotation	0° ~ 190°				
Max. rotation angle	190°				
Temperature range	0°C(32°F) ~ +60°C(140°F)				
Lubrication	None required				
Typical rotational speed	(No load - 71 psi) 0.2 ~ 1 Sec/90°				
Output torque	See chart on page 6				
Weight (g)	1100	1400	2200	3800	6200

Conversions  
 psi = kgf/cm<sup>2</sup> x 14.2  
 psi = MPa x 145  
 inch = mm x 0.0394  
 ounceforce-in = kgf-cm x 13.9  
 ounce = g x 0.035

## Price List

Rotation Angle	FRC16	FRC20	FRC25	FRC32	FRC40
180°	\$300.05	\$333.80	\$377.35	\$484.65	\$672.30
Shock Absorber	FSC1008-1NC \$32.65	FSC1008-1NC \$32.65	FSC1415-3NC \$47.15	FSC1415-3NC \$47.15	FSC1415-3NC \$47.15

These shock absorbers are sized for general conditions and should be suitable for a wide variety of applications. Extreme loads or speeds may require other shock absorbers sizes.

Sensor Selection Guide		Prewired 9 ft. Leadwire Part No.	Price	Quick Disconnect* Part No.	Price
Reed (LED)	5-120 VDC/VAC, 0.03 Amp Max current, 4 Watt Max, 2.0 voltage drop	9Q49-000-002 . . .	\$19.25	9Q49-000-302 . . .	\$21.75
Electronic (LED)	Sourcing PNP 5-28 VDC, 0.20 Amp Max current, 0.5 Voltage Drop	9Q49-000-031 . . .	32.30	9Q49-000-331 . . .	34.80
Electronic (LED)	Sinking NPN 5-28 VDC, 0.20 Amp Max current, 0.5 Voltage Drop	9Q49-000-032 . . .	32.30	9Q49-000-332 . . .	34.80

\*Note: Quick disconnect styles are supplied with 6 inch pigtail with male connector.

## Features

1. **Magnetic pistons are standard on all models.**
2. Compact design saves space.
3. Rectangular body design has end caps with ports and adjusting screws.
4. Rack and pinion mechanism designed to minimize backlash.
5. Rotation adjustment screws are standard.
6. **Adjustable air cushions are standard on all models.**
7. Cushioning with shock absorbers is available.

## How to order

**FRC** Series  
**20** Bore x **180** Rotation angle  
 FRC standard type

Available Bore Sizes: ø16, ø20, ø25, ø32, ø40

Available Rotation Angles: 180°

## Position Sensors

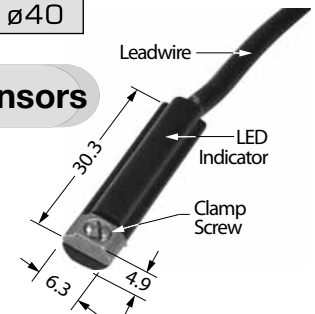

See specifications in the sensor selection guide below. Please order sensors and female cordsets separately.

Female Cord Sets	Part No.	Price
1 Meter	CFC-1M	\$14.35
2 Meters	CFC-2M	16.05
5 Meters	CFC-5M	20.30

## Construction

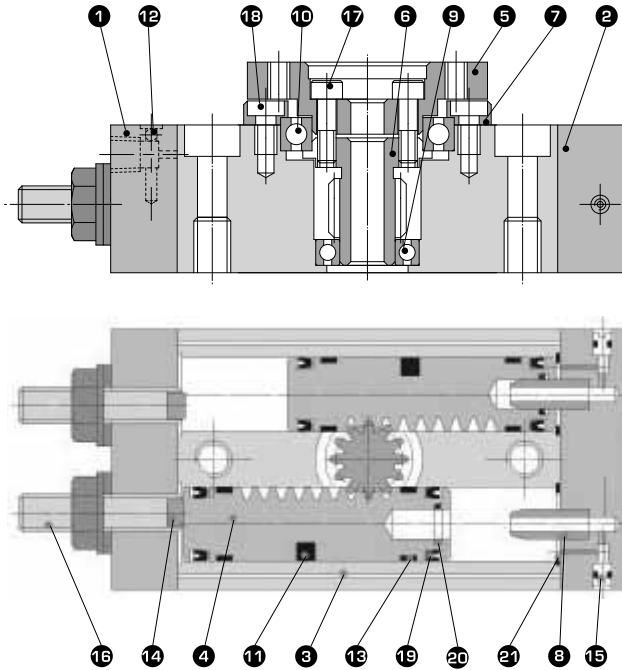

- 15** Adjustable air cushions are standard on all models. Engagement is approximately 45° before each end of full 180° rotation on all bore sizes.

**ADJUSTING SCREWS ARE NOT RETAINED.  
 USE CAUTION WHEN MAKING ADJUSTMENTS.**

- 16** Shock absorbers can be substituted in place of the adjustable screws on all bore sizes and used as hard stops for rotational adjustment. See "How to Order" page 4 for shock absorber selection.

## Part lists

NO	Description	Material	Qty
1	Front end cover	Aluminum black anodized	1
2	Rear end cover	Aluminum black anodized	1
3	Housing	Hard anodized aluminum alloy	1
4	Rack	Stainless steel	2
5	Gear cover	Aluminum alloy	1
6	Pinion	Case hardened alloy steel	1
7	Bearing cover	Aluminum alloy	1
8	Rear cushion spear	Aluminum alloy	2
9	Ball bearing	High carbon - high chrome bearing steel	1
10	Ball bearing	High carbon - high chrome bearing steel	1
11	Magnet	Magnet material	4
12	Steel ball	Medium carbon steel	4
13	Wear ring	Fluoride resin	4
14	Bumper	Plastic	2
15	Cushion needle screw	Stainless steel	2
16	Adjustable screw	Medium carbon steel	2
17	Hexagon screw	Medium carbon steel	8
18	Screw	Medium carbon steel	6

## Seals list

NO	19	20	21
Bore	Seal	Cushion seal	End cover seal
ø16	DYP16	CIM6	SM18
ø20	DYP20	PDF8	SM21
ø25	DYP25	PDF09	SM25
ø32	APP32	DF14	SM32
ø40	AGP40	DF14	SM42

## Rotation direction & adjusting instruction

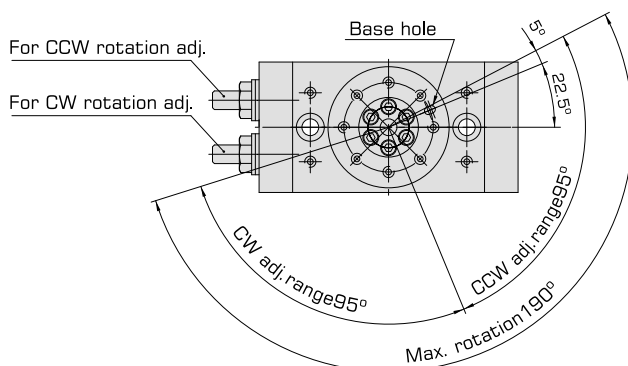

## Inertia force and rotation time

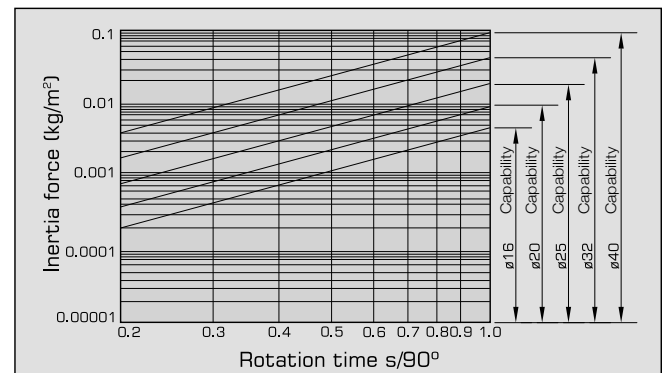

## Allowable load

Conversions:  
 lb = N x 0.224  
 lbf·ft = N·m x 0.738

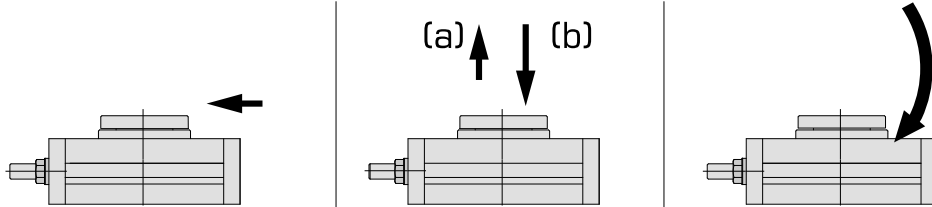

Bore mm	Allowable side load on shaft N (lb)	Allowable axial load N (lb)		Allowable moment N·m (lbf·ft)
		(a)	(b)	
16	88(19)	84(18.8)	88(19)	2.7(1.99)
20	178(40)	179(40)	330(74)	3.9(2.87)
25	314(70)	296(66)	451(101)	9.7(7.15)
32	390(87)	493(110)	708(159)	18(13.2)
40	543(122)	740(166)	1009(226)	25(18.4)

## Output

lbf-in  
 (kgf-cm)

Bore	16	20	25	32	40
50 psi (0.35MPa)	9 (10.4)	16.5 (19.0)	27 (31.0)	54 (62.2)	112 (129)
100 psi (0.7MPa)	18 (20.8)	33 (38.0)	54 (62.1)	108 (124.4)	225 (259)

Conversions:  
 MPa = psi x 0.7  
 kgf-cm = lbf-in x 1.15

## Rotation adjusting range

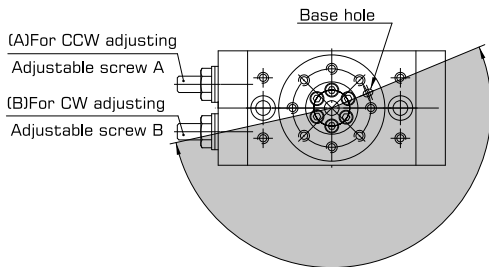

**Max. Rotation 190°**

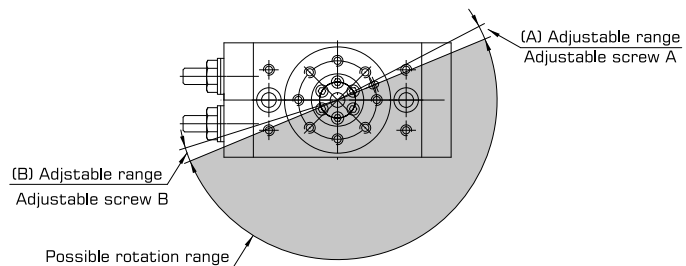

**180° Rotation**

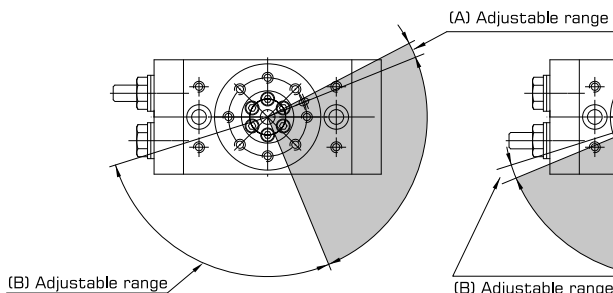

**90° Rotation**

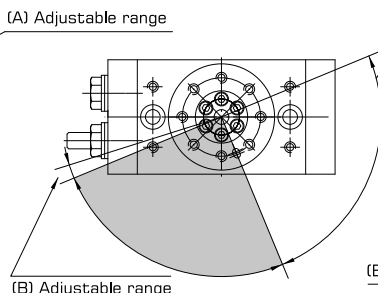

**90° Rotation**

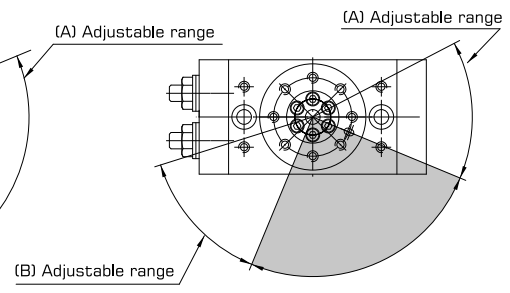

**90° Rotation**

# FRC Series ROTARY ACTUATOR

## Dimensions (mm)

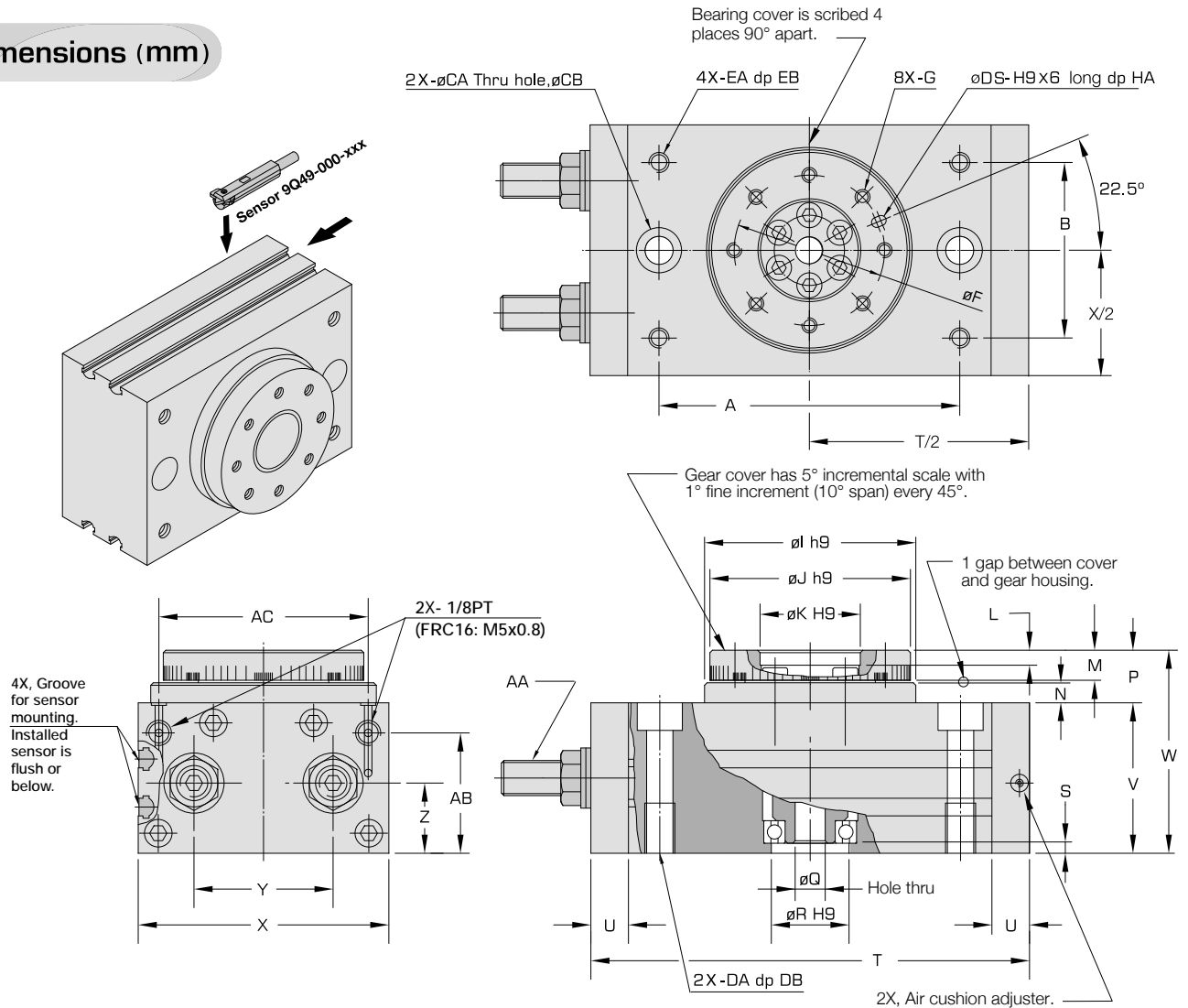

Model	A	B	CA	CB	DA	DB	DS	EA	EB	$\varnothing$ F	G	HA	$\varnothing$ l	$\varnothing$ J	$\varnothing$ K	L
FRC16	76	34	8.6	14	M10X1.5	15	4	M6X1.0	8	43	M6X1.0	4.5	61	60	27	6
FRC20	84	37	8.6	14	M10X1.5	15	4	M6X1.0	8	48	M6X1.0	4.5	67	65	32	4.5
FRC25	100	50	10.2	18	M12X1.75	15	5	M8X1.25	8	55	M8X1.25	6	77	75	35	5.5
FRC32	120	70	10.2	18	M12X1.75	20	4	M8X1.25	8	70	M8X1.25	6	92	90	40	6
FRC40	140	80	10.2	18	M12X1.75	20	4	M8X1.25	12	80	M8X1.25	6	102	100	45	6

Model	M	N	P	$\varnothing$ Q	$\varnothing$ R	S	T	U	V	W	X	Y	Z	AA	AB	AC
FRC16	10	6	17	9	17	2	119	13	37	54	65	27.5	15.5	M10X1.0	28.5	50
FRC20	10	6	17	9	22	2	131	14	40	57	70	29	18.5	M10X1.0	32	50
FRC25	12	7	20	10	26	3.5	157	18	46	66	80	36	22	M14X1.5	37.5	63
FRC32	12	8	21	12	31	4	175	15	60	81	100	50	28	M14X1.5	48	83.5
FRC40	12	8	21	18	36	4	195	15	70	91	122	65	33	M14X1.5	58	100

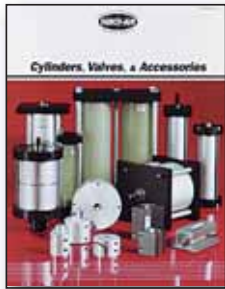

Cylinders, Valves and Accessories  
 Catalog #CV9

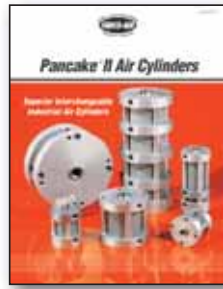

Pancake® II Air Cylinders  
 Catalog Pan2-2



Square Pancake® II Air Cylinders  
 Catalog # SqPan2



ISO 6431 Cylinders  
 Catalog # FAQR-09



Twin Rod, Non-Rotating Air Cylinders - Catalog # FDF-09 and Catalog # FDXS-09



Multi-Power® Air Presses  
 Catalog # FP16



Linear Slides - 6 Families  
 Catalog # LS-03



Pneumatic Grippers, Parallel Jaw and Angular Motion - Catalog # GR-8



Pneumatic Angular Grippers  
 Catalog # FKA-09

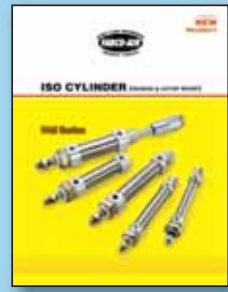

ISO 6432 Cylinders  
 Catalog # FAE-09



NFPA Interchangeable Air Cylinders - Catalog # NF-6

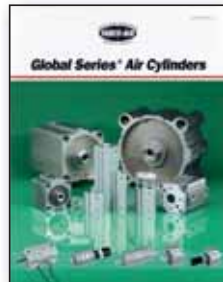

Global Series™ Metric Air Cylinders - Catalog # GC-15



Swing Clamps  
 Bulletin # SC-DB04



Manifold Solenoid Valves  
 Catalog # FVS-Y-09

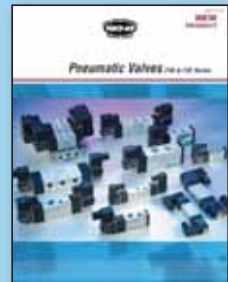

Air Pilot & Solenoid Valves  
 Catalog # FVA-E-09



Modular Air Preparation System - FRLs  
 Catalog # FRL-06



Specialty & Control Valves  
 Catalog # 14CAN



Stopper Cylinders  
 Catalog # ST-SC

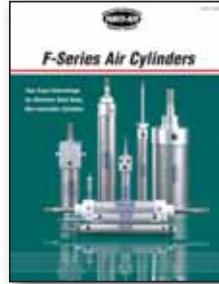

Stainless Steel Body Air Cylinders  
 Catalog # SSB-03



Swing Clamps, Pneumatic & Hydraulic  
 Catalog # FML-H

Check out these new product lines today !